

AIPER[®]

— bring vacation home —

CORDLESS ROBOTIC POOL CLEANER

User Manual

Original Instructions

Aiper Scuba N1600

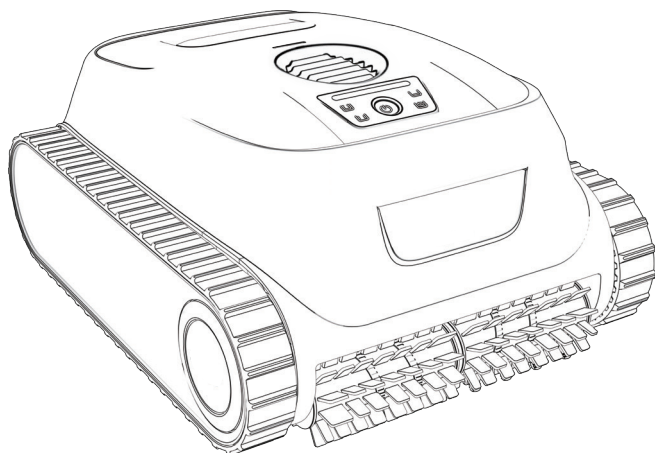

Thank you for choosing Aiper.

You've now joined millions who have already trusted Aiper to care for their pools and are enjoying the convenience of a pristinely clean pool.

This user manual will help you maintain your device and ensure it performs at its maximum efficiency for years to come. Please take a moment to read through it.

If you have any questions, please visit our website at www.aiper.com and contact our customer service team for assistance or more information.

Aiper Customer Service:



Email: service@aiper.com



Scan for
Video Guide



Scan the QR
Code to Access
Customer Support

1. IMPORTANT SAFETY INSTRUCTIONS

Please read this manual carefully and follow all warnings and instructions when using your Aiper Cordless Robotic Pool Cleaner (hereinafter referred to as *device*). Failure to comply may result in electric shock, fire, or serious injury. Aiper is not liable for any losses or injuries caused by improper use of this device.

For your safety and the optimal performance of this device, please read and follow these instructions:

1. This device is not intended for use by persons (including children) with reduced physical, sensory or mental capabilities, or lack of experience and knowledge, unless they have been given supervision or instruction concerning use of the device by a person responsible for their safety.
2. Children shall not play with the device. Cleaning and user maintenance shall not be made by children without supervision.
3. Children should be supervised to ensure that they do not play with the device.
4. Ensure that children do not attempt to touch the device while it is operating.
5. Do not allow children to ride the device under any circumstance.
6. Do not operate the device with people or animals in the pool.
7. While operational, do not place your hands into any part of the device as this may result in injury.
8. Do not run your device out of the water as it may lead to over-heating.
9. A charger that is suitable for one type of battery pack may create a risk of fire when used with another battery pack.
10. **WARNING:** For the purposes of recharging the battery, only use the detachable supply unit provided with this device.
11. The lithium battery in this device is a DC 14.4V, 7800mAh, 12-cell battery, compatible with charger model GC44-168260-2C. The battery must be removed and discarded according to local laws and regulations before disposing of the device.
12. This device can only be used with C1264C5 model lithium battery packs.
13. The device contains batteries that are only replaceable by skilled persons. To replace the device's battery, please contact Customer Service.
14. This device contains batteries that are non-replaceable. When the battery is at end of life, the device shall be properly disposed of.
15. Be aware of the risk of terminals of the battery-operated device or battery being short-circuited by metal objects.

16. In the event a damaged device produces an unfamiliar liquid, avoid contact with the liquid. If coming into contact with a foreign liquid, especially the eyes or other sensitive parts, immediately flush with water. Liquid ejected from a damaged battery may cause skin irritation or burns.
17. Do not expose the device or battery to fire or excessive temperature. Exposure to fire or temperature above 130°C(265°F) may cause explosion.
18. Remove the device from the charger, and turn OFF the power button to the device before removing the battery for disposal of the device .
19. The battery must be removed and discarded according to local laws and regulations before disposal of the device .
20. Please dispose of used batteries according to local laws and regulations.
21. Do not incinerate the device even if it is severely damaged. The batteries can explode in a fire.
22. Ensure your device is turned off and the charging port is dry before charging with the charger. While charging, your device should be kept in a cool, well-ventilated area. Do not cover your device while charging, as this may cause components to overheat.
23. WARNING: To reduce the risk of electric shock, replace damaged cord immediately.
24. If the power cord is damaged, it must be replaced or repaired by a qualified electrician or Aiper Customer Care to avoid any hazards.
25. The power supply is not to be repaired and not to be used any longer if it is damaged or defective.
26. Only certified professionals should disassemble the sealed drive kit of your device.
27. Only use as described in this manual. Only use attachments recommended or sold by the manufacturer.
28. Do not operate your device simultaneously with any other pool equipment, such as a pool filter, cleaner, or skimmer.
29. When putting your device into the water, the front of the device must face upwards and should never be placed upside down or thrown into the swimming pool.
30. Watch your steps and maintain balance when working near the poolside.
31. Do not drop, pierce the shell, or intentionally damage the device in any way, as this may void your warranty.
32. Disconnect the robotic pool cleaner from the supply mains before carrying out user maintenance such as cleaning the filter.
33. The plug must be removed from the receptacle before cleaning or maintaining the charger.

34. When not using the charger for a long period of time, please unplug it.
35. When not in use, store the device indoors, in a cool, well-ventilated area.
36. CAUTION:
- FOR USE WITH SWIMMING POOLS ONLY.
 - DO NOT RUN PUMP DRY.
 - FOR USE ONLY WITH AUTHORIZED AIPER CHARGER, MODEL: GC44-168260-2C.

SAVE THESE INSTRUCTIONS

2. Product Components

2.1 Package Contents

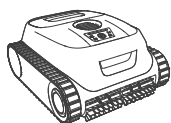

Robotic Pool Cleaner *1

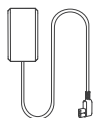

Charger *1



Hook *1



User Manual *1

2.2 Component Overview

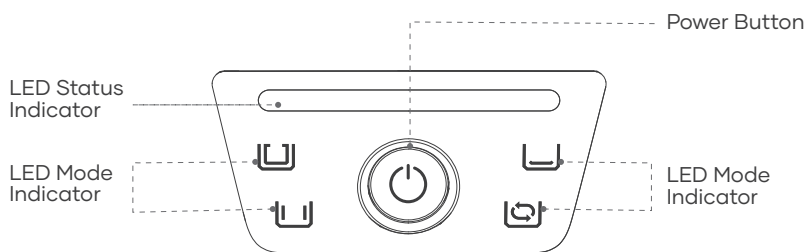

Control Panel

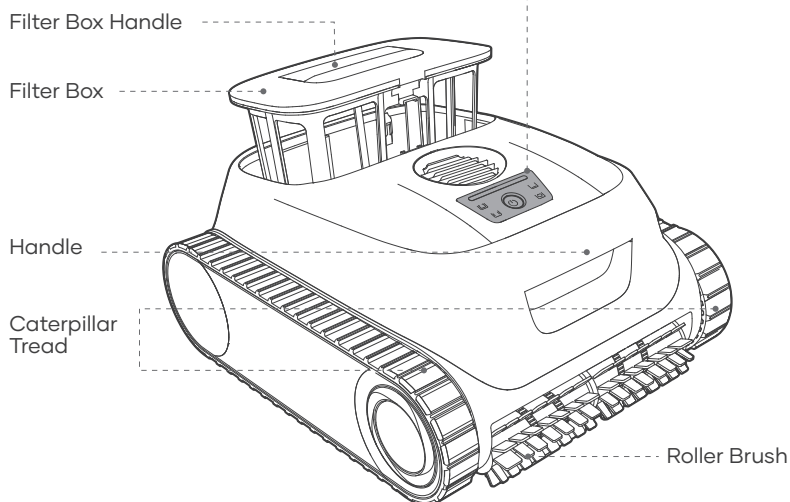

Robotic Pool Cleaner (Side View)

3. How to Use Your Aiper Scuba N1600

3.1 Operating Conditions

Please ensure the device is only used within the specified pool environments. Damage resulting from use outside these conditions will not be covered under warranty.

• Water Temperature	10-40°C (50-104°F)
• pH Value	7.0-7.8
• Chlorine	Maximum 4 ppm
• NaCl	Maximum 5 000 ppm

3.2 Charging

CAUTION:

Please fully charge the device before using it to clean the pool.
Do not charge the device in direct sunlight.

Charging Option:

Before charging, remove the charging port cover and ensure the charging port is dry. If there's any water or dampness in the port, wipe it dry with a clean cloth before charging your device.

Use the provided DC charger. Connect the charger to the device's charging port, then plug the charger into any available outlet. The LED status indicator will pulse while charging and turn solid green when fully charged.

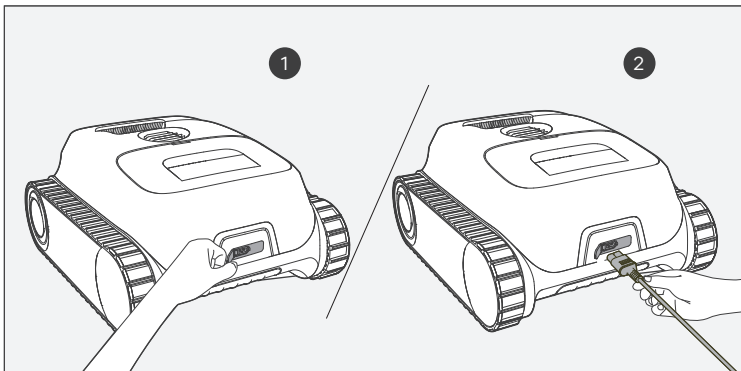

3.3 Choosing Filter

Two filters of different thickness are provided: replaceable MicroMesh™ ultra-fine filter and filter box.

The replaceable MicroMesh™ ultra-fine filter can trap particles as small as 3-10µm, such as silt and some algae. When visible debris is minimal (e.g., stones, leaves, sand, debris, hair) and the water appears cloudy or some algae, it is recommended to use both the filter box and the replaceable MicroMesh™ ultra-fine filter.

If there is a significant amount of visible debris, it is recommended to use only the filter box and not use the replaceable MicroMesh™ ultra-fine filter.

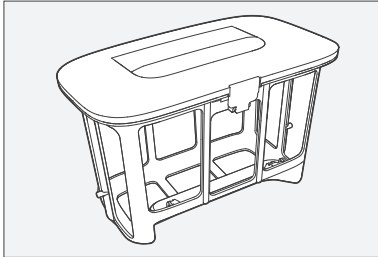

Filter Box

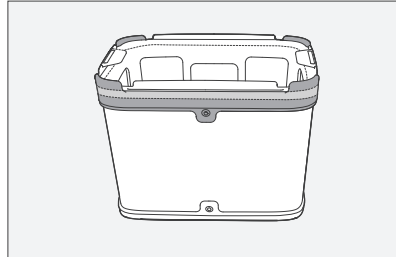

Replaceable MicroMesh™
Ultra-fine Filter

3.4 Cleaning Process

1. Press and hold the  Button for 2 seconds to turn on/off the device.

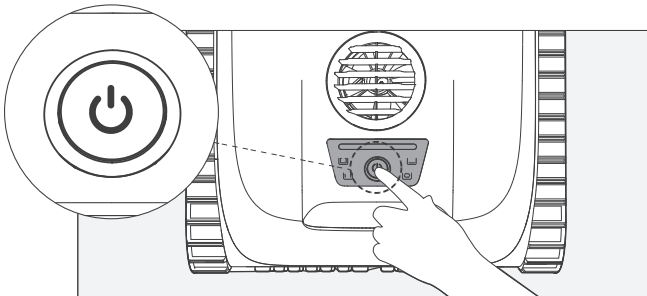

2. By default, the device starts in Smart Mode. Press the  button briefly to cycle through and choose one of the four cleaning modes: Smart Mode, Floor Mode, Wall Mode, and Periodic Mode.

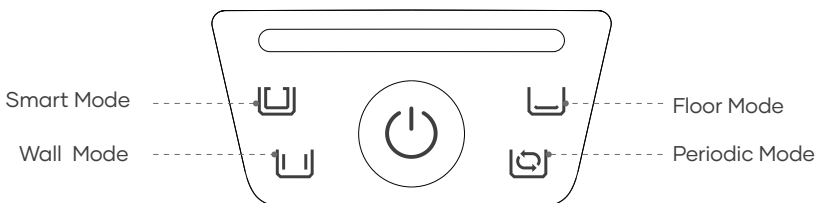

After powering on the device and selecting a cleaning mode, submerge the device into the pool within 30 seconds to prevent automatic shutdown. Once the device has reached the pool floor, it will begin the selected cleaning program within 10 seconds of floor contact.

The details of each cleaning mode are described below :

- Smart Mode: The device will clean your pool walls and pool floor sequentially, planning its path based on the battery level.

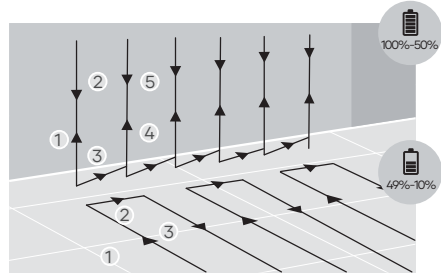
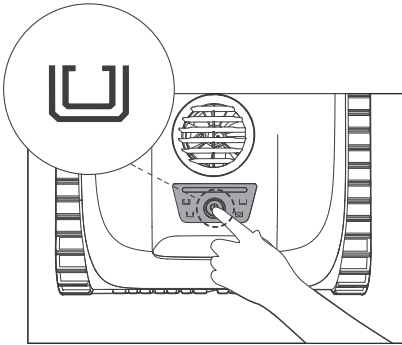

Smart Mode

- Floor Mode: The device will clean the pool floor in an S-shaped route, without climbing or cleaning walls.

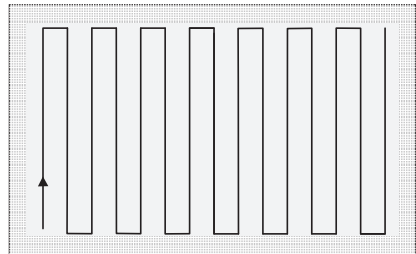
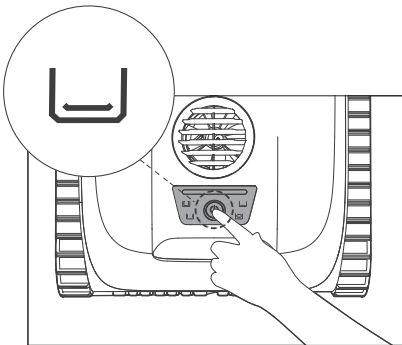

Floor Mode

- **Wall Mode:** The device will clean the pool walls utilizing an N-shaped route. The device will not clean the pool floor in the mode.

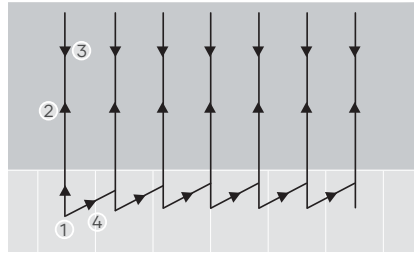
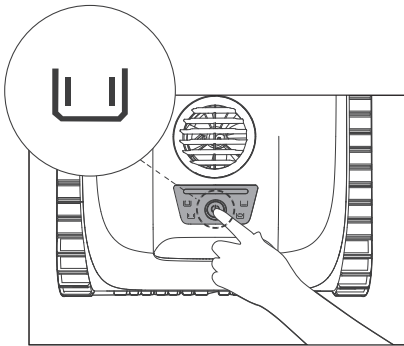

Wall Mode

- **Periodic Mode:** When fully charged, the device will automatically clean the pool floor every 48 hours for a week, with each session lasting for 45 minutes.

To stop Periodic Cleaning and switch to another cleaning mode, remove the device from your pool in a non-cleaning situation. Press the  button to cycle through and select the desired cleaning mode and place your device back into the pool. The device will now clean according to the selected plan.

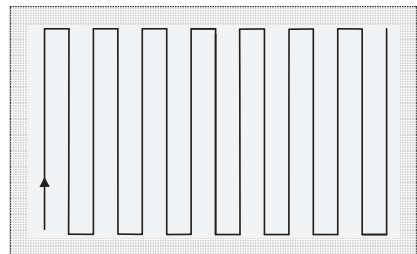
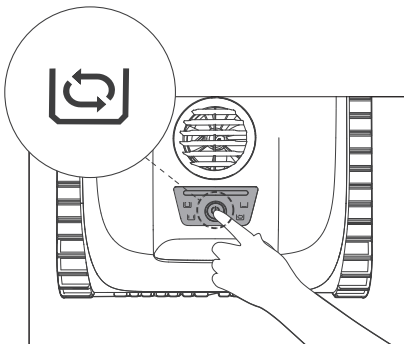

Periodic Mode

3. When the battery level is low, indicated by a solid red LED status indicator, the device will stop the current cleaning task and automatically park at the edge of the pool.

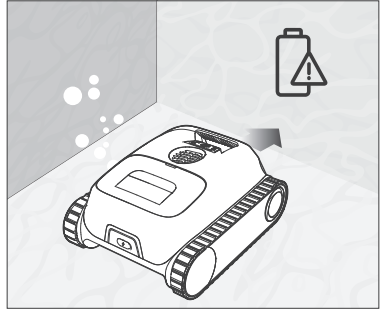

4. Users can attach the hook to any standard telescopic pool pole (not included) to extend, hook, and pull up the device from the pool floor.

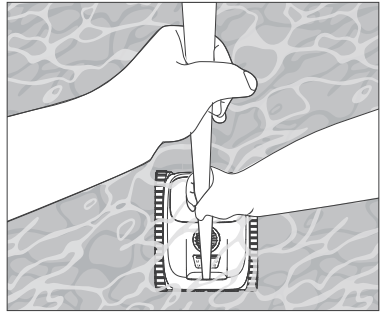
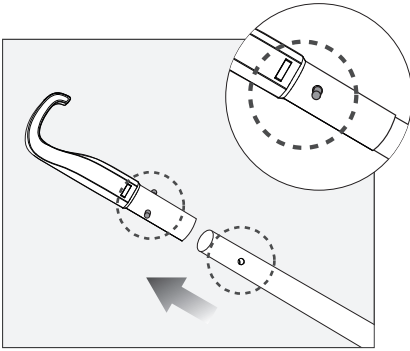

5. Allow the device to drain any stored water before storing or charging the device.

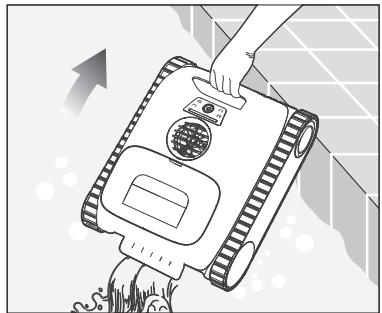

4. Maintenance

4.1 Cleaning the Filter Box

1. Place the device on a flat surface.
2. Hold the device with one hand and use the other hand to lift the handle of the filter box to remove it.

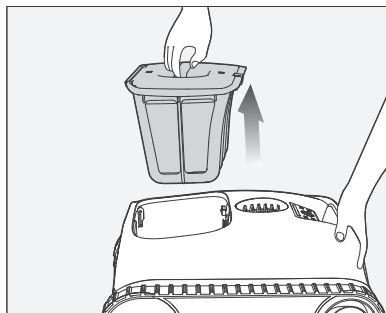

3. Press the latch on the filter box and lift the top shell handle to open it.

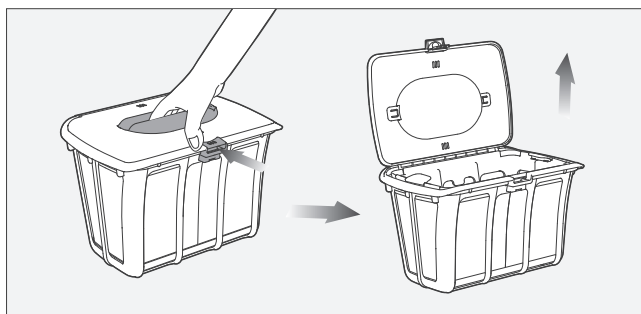

4. Empty the filter box and remove the replaceable MicroMesh™ ultra-fine filter.

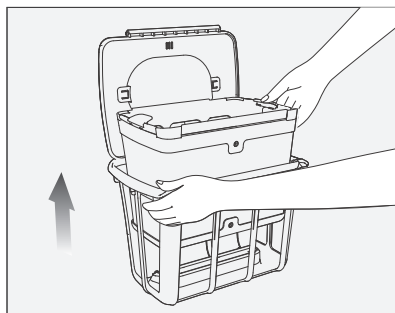
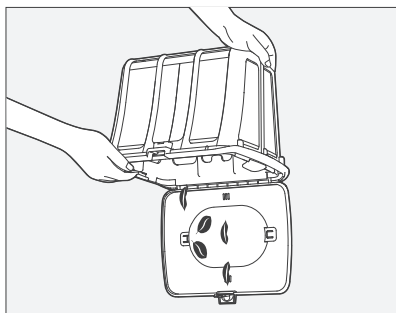

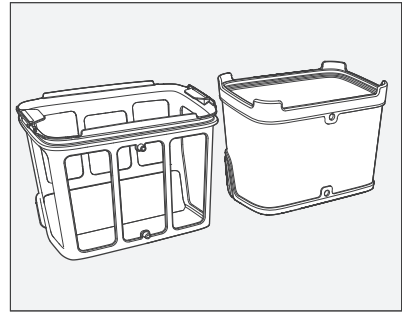
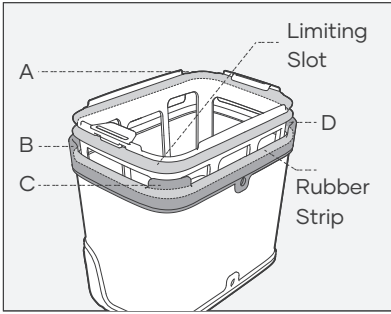

Remove the A, B, C, and D latches on the replaceable MicroMesh™ ultra-fine filter rubber strip from the limiting slot.

5. Rinse the replaceable MicroMesh™ ultra-fine filter and filter box separately.

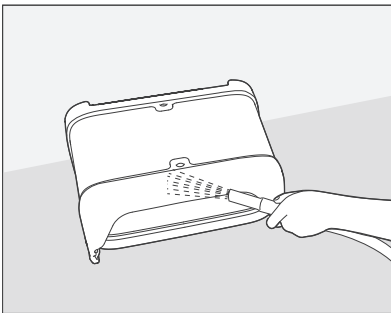
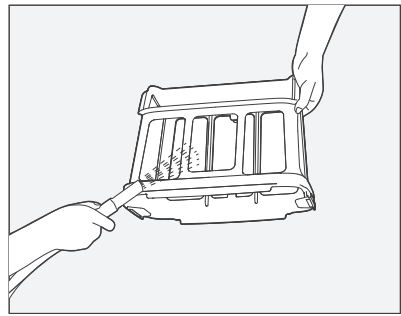
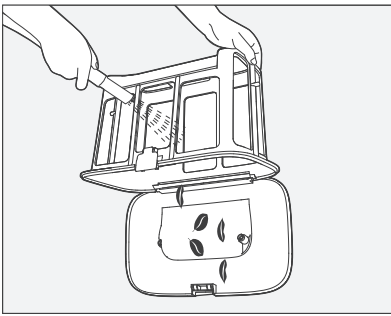

The replaceable MicroMesh™ ultra-fine filter needs to be rinsed inside and outside. Scrub it by hand if necessary.

6. After drying the replaceable MicroMesh™ ultra-fine filter and filter box, install the filter in the filter box, and insert the filter box back into the device.

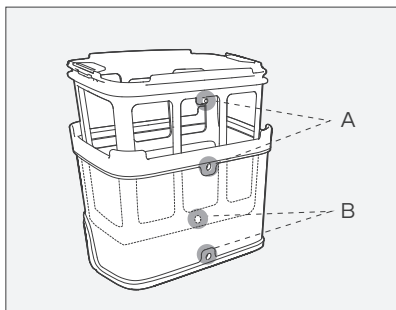

Ensure that A and B on the filter box are aligned with A and B on the replaceable MicroMesh™ ultra-fine filter.

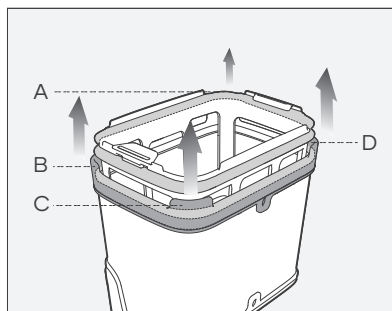

Pull up the four corners A, B, C, and D on the rubber strip in turn. Ensure that they are stuck in the limiting slot of the replaceable MicroMesh™ ultra-fine filter.

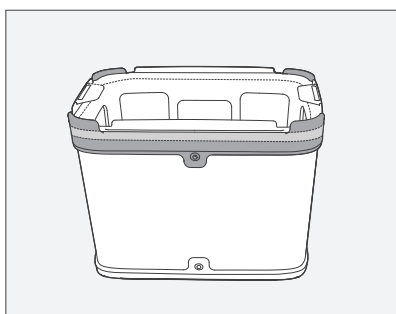

After installation, check whether the rubber strip is all stuck into the limiting slot.

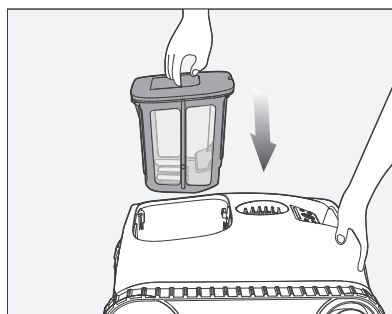

7. Once reinserted, ensure that the filter box is secure. Gently pull up on the handle to confirm that the device is locked into place.

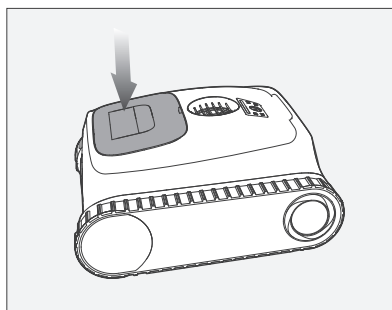

Notes:

- After each cleaning task, promptly remove the device from the pool and clean the filter box immediately. Avoid leaving the device in the pool for extended periods.
- Drying the replaceable MicroMesh™ ultra-fine filter and filter box after each cleaning is not required and is recommended solely to prevent moisture-related odors.
- When drying or storing your device, including the replaceable MicroMesh™ ultra-fine filter and filter box, it's recommended to store them in a well-ventilated area, out of direct sunlight.
- The replaceable MicroMesh™ ultra-fine filter can trap particles as small as 3-10µm, such as silt and some algae. When visible debris is minimal (e.g., stones, leaves, sand, debris, hair) and the water appears cloudy or some algae, it is recommended to use both the filter box and the replaceable MicroMesh™ ultra-fine filter. If there is a significant amount of visible debris, it is recommended to use only the filter box and not use the replaceable MicroMesh™ ultra-fine filter.
- It is advisable to use a high-pressure water gun to clean the replaceable MicroMesh™ ultra-fine filter and the filter box to ensure thorough cleaning.
- After several uses, the surface of the replaceable MicroMesh™ ultra-fine filter may show signs of wear, this does not impact its performance.
- The replaceable MicroMesh™ ultra-fine filter is a consumable item and should be replaced about every 30 uses to maintain effective filtration.

4.2 Cleaning the Propeller

1. Use a flathead screwdriver to pry open the drain cover.

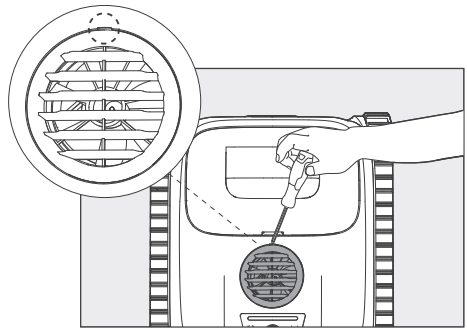

2. After removing the drain cover, remove the propeller cover to expose the propeller.

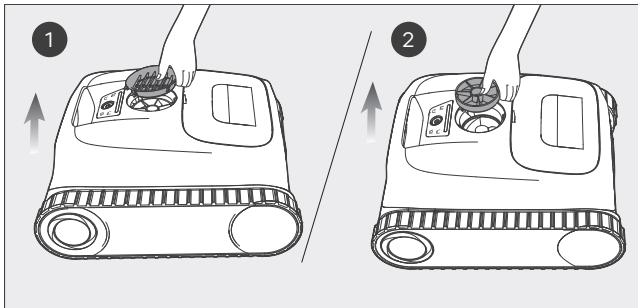

3. Remove any debris entangled in the propeller.

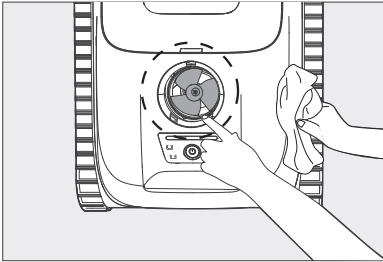

4. After cleaning the propeller, reattach the propeller cover.

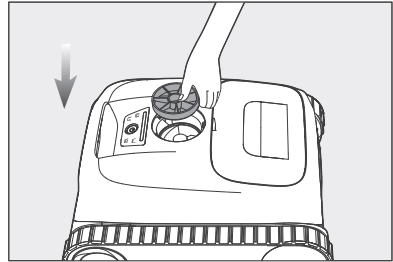

5. Align the A, B, and C clips on the drain cover with those on the device. Insert the A and B clips of the drain cover into the device, and then press down on the C clip until it is securely fastened.

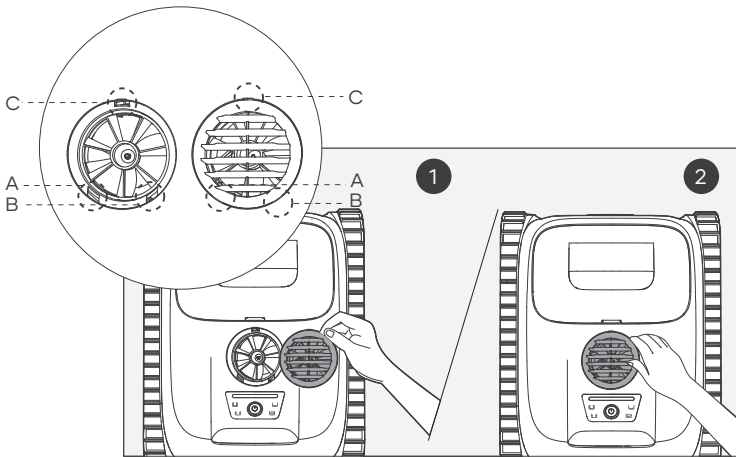

4.3 Replacing the Caterpillar Tread

1. Remove the side cover plate from the device: Lay the device on its side, remove the 4 clips on the side cover plate with the flathead screwdriver, and pull out the side cover plate upwards.

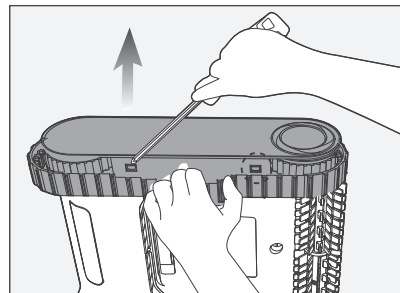

2. Remove the screws and the guide sleeve from the rear wheel.

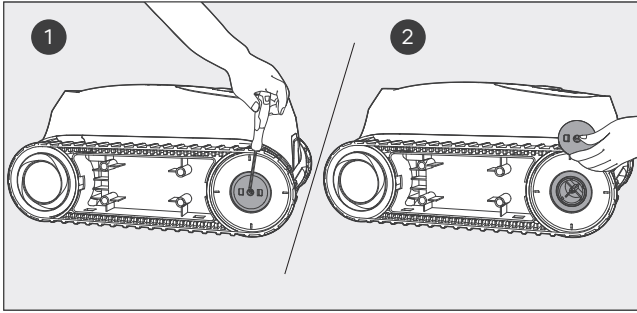

3. Remove the rear wheel and caterpillar tread of the device by gently pulling on each piece.

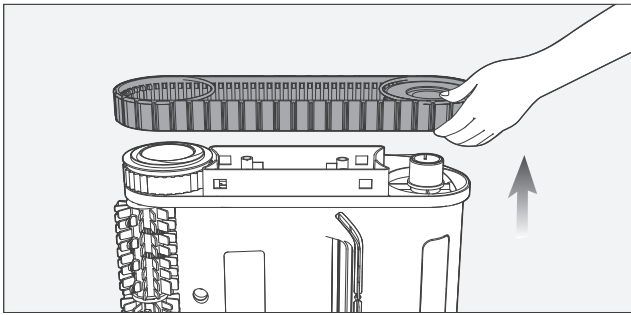

4. Align the gears of the replacement caterpillar tread with the gears on both wheels. Reinstall the rear wheel and the caterpillar tread, ensuring they are secured along the tread sleeves.

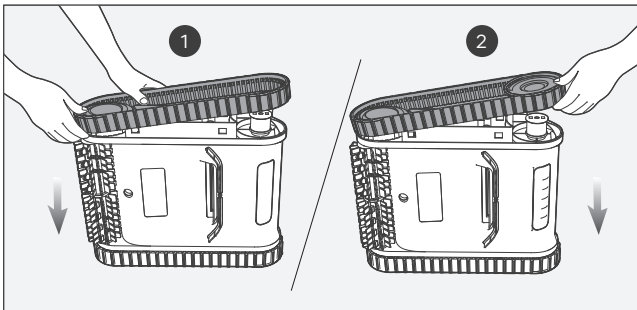

5. Install the rear wheel guide sleeve, ensuring the top of the three shafts aligns with the hole on the device.

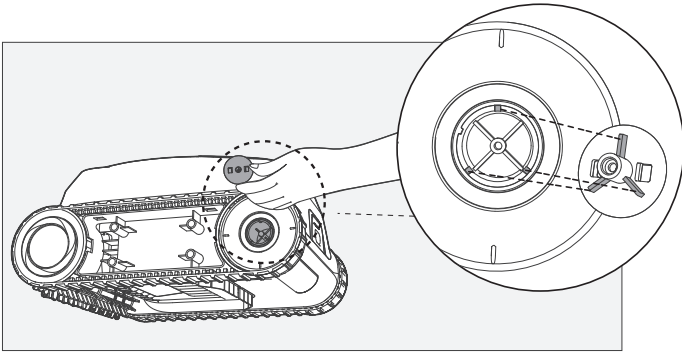

6. Tighten the screws and re-install the side cover plate. Repeat this step for the other caterpillar tread.

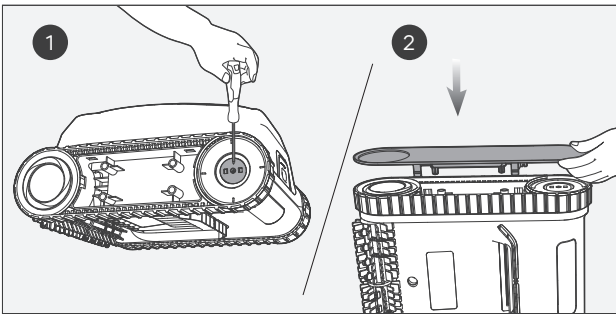

4.4 Replacing the Roller Brush

1. Remove all the silicone buckles from your current roller brush.

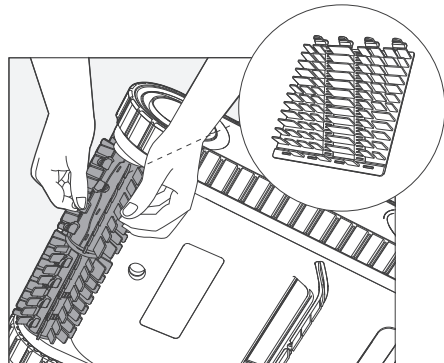

2. Once removed, grab your replacement roller brush and align the silicone buckles with the slots. Press the buckles into each slot to secure the new roller brush to your device. Repeat this step for the other roller brush.

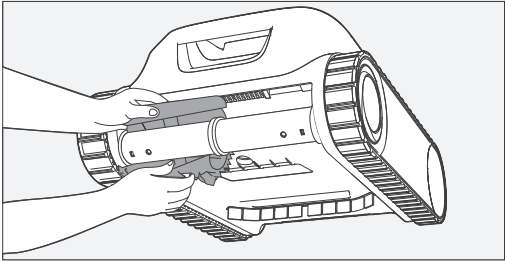









4.5 Powering Off and Storing Your Aiper

During off-seasons, such as winter or long vacations, when your Aiper device isn't in use, follow these steps to keep it in top shape:

1. Fully charge the device before storing it. Ensure the device is turned off and disconnected from the charger before storing.
2. Thoroughly clean the entire device, including the top and bottom shells, wheels, brushes, and charging port to remove any dirt.
3. Dry the device with a tissue or soft cloth, and ensure the charging port cover is properly closed.
4. Store the device in its original packaging in a cool, dry, and well-ventilated place.
5. Recharge the battery every six months to maintain its health.

5. Specifications

Model: PRE1
Pool Size: 1 600 Sq.Ft (150m ²)
Rated Input: 16.8V==2.6A
Charger Model: GC44-168260-2C
Charger Input: 100-240V~, 50/60Hz, 1.5A
Charger Output: 16.8V==2.6A
Charging Time: 3-4 Hours
Suction Power: 15000 LPH (3 960 GPH)
Battery Pack Life: 150 Minutes
Battery Pack Capacity: 7 800mAh (112.32Wh)
Battery Pack Voltage: 14.4V
Water Protection Rating: IPX8
Max Water Depth: 3m (10 ft)
Frequency Range: 2.400–2.483 GHz, Maximum E.I.R.P: 20 dBm

	Direct current.
	Alternating current.
	Class II equipment.
	Switch mode power supply.
	Polarity of d.c. power connector.
	Short-circuit-proof safety isolating transformer.
	For indoor use only.
	If the pins of the plug parts are damaged, the plug-in power supply shall be scrapped.
	Read user's manual.

6. LED Status Indicator

Indicator Status	Device Status	Status Description
Pulsing Red	Charging	Charging (Battery < 15%).
Pulsing Blue		Charging (Battery 15-50%).
Pulsing Green		Charging (Battery > 50%).
Solid Green		Charging Complete.
Solid Red	Standby or Cleaning	Low battery (Battery < 15%). Task will stop, and the device will automatically park at the edge.
Solid Blue		Moderate Battery Level (Battery 15-50%).
Solid Green		Operating normally (Battery > 50%).
Flashing Red and Yellow Alternately	Fault or Error	Refer to the <i>Troubleshooting</i> section for details.
Flashing Red and Blue Alternately		
Flashing Red and Green Alternately		
Flashing Yellow		
Flashing Red		

7. Troubleshooting

NO.	Malfunction	Possible Causes	Solutions
1	Device doesn't turn on.	Insufficient battery power.	Fully charge the device before attempting to clean your pool.
		Battery temperature too high/low.	Only operate the device in an environment between 10°C (50°F) and 40°C (104°F).
2	Device not charging.	Charger is not powered or get damaged.	Check if the charger plug is securely connected and if the indicator light on the charger is lit. If the plug is properly connected but the light is off, the charger might be faulty. Please contact Aiper customer service.
		Battery temperature too high/low.	Only operate the device in an environment between 10°C (50°F) and 40°C (104°F).
		Extended non-use of the device has caused the battery to discharge.	Follow the <i>Powering Off and Storing Your Aiper</i> section in the <i>Maintenance</i> guide for proper storage of the device. If the device won't charge due to extended non-use, please contact Aiper customer service.
3	Device remains on the pool drain for too long.	The device has been caught by the pool drain.	Do not open the pool drain while the device is cleaning. If stuck, the device will free itself.
4	Device tilts or loses cleaning efficiency in water.	Filter box is full.	Please empty and thoroughly clean the filter box.
		Replaceable MicroMesh™ ultra-fine filter is clogged.	Please rinse the filter with a high-pressure water gun.
		The propeller may be jammed.	Check for any debris on the Propeller and clean it if needed. For details, refer to the <i>Maintenance</i> section for <i>Cleaning the Propeller</i> .

5	Device does not climb the pool walls.	Filter box is full.	Please empty and thoroughly clean the filter box.
		Replaceable MicroMesh™ ultra-fine filter is clogged.	Please rinse the filter with a high-pressure water gun.
		Device is in Smart Mode, but the battery level is below 50%.	Fully charge the device, and then operate it again in Smart Mode.
6	Device has stopped working.	If the LED status indicator is flashing red and yellow alternately, the water pump motor may be jammed or malfunctioning.	Check for any debris on the propeller and clean it if needed. For details, refer to the <i>Maintenance</i> section for <i>Cleaning the Propeller</i> .
		If the LED status indicator is flashing red and blue alternately, the left drive motor may be jammed or malfunctioning.	Check if there is any debris entangled around the roller brush and clean it if needed. If the roller brush still does not rotate, please contact Aiper customer service.
		If the LED status indicator is flashing red and green alternately, the right drive motor may be jammed or malfunctioning.	
		If the LED status indicator is flashing yellow, the device may be stuck.	Wait for the device to free itself or manually remove it from the stuck area.
		If the LED status indicator is flashing red, the battery temperature may be too high/low.	The device will stop the current task until the temperature returns to a safe level, and then resume working.

8. Warranty

This product has passed quality control and safety test conducted by our technicians.

1. This product comes with a warranty that covers your item's battery and motor from the date of purchase. The respective country's legal provisions for warranty conditions shall apply accordingly.
2. This warranty is voided if the product has been altered, misused, or has been repaired by unauthorized persons.
3. This warranty extends only to manufacturing defects and does not cover damage resulting from the mishandling of the product by the owner.
4. The order number or record of purchase must be presented at the request of any repair claim during the warranty period.
5. This is an additional warranty offered by AIPER INTELLIGENT SARL, 43-47 avenue de la Grande Armée, 75116 Paris, France. This warranty does not affect the free of charge remedies for lack of conformity that the consumer holds against the seller, according to law.
6. Warranty Email: service@aiper.com

Declaration of Conformity (CE)

Shenzhen Aiper Intelligent Co., Ltd. hereby declares that this product complies with all the requirements of the applicable EU directives 2014/53/EU & 2011/65/EU. – The full text of the Declaration of Conformity is available by visiting the following link:
<https://aiper.com/declaration-of-conformity>

The EU declaration of conformity can be requested via the address below:
 AIPER INTELLIGENT SARL
 43-47 avenue de la Grande Armée, 75116 Paris, France



Points de collecte sur www.quefairedesdechets.fr
 Privilégiez la réparation ou le don de votre appareil !

Points de collecte sur www.quefairedesdechets.fr
 Privilégiez la réparation ou le don de votre appareil !



This symbol indicates that this product shall not be treated as household waste. Instead it shall be handed over to the applicable collection point for the recycling of electrical and electronic equipment.

AIPEER®

— bring vacation home —



040401.0175-1219

www.aiper.com